



Product Information



DEKOMAT[®] 1

Hand wrapping device for the application of BUTYLEN-Tapes with 41 mm core.

Description

The DEKOMAT is a hand wrapping machine that allows cold-applied BUTYLEN-Tapes to be spirally wrapped around pipes and pipe bends.

The machine ensures a uniform wrapping tension and a constant width of overlap. The DEKOMAT can be used on all straight pipes and on all pipe bends suitable for pigs. It can also be used on the welded joints of factory polyethylene or with other material coated steel pipes of diameter 80 mm upwards.

All BUTYLEN Tapes of the types "AS", "S", "N", "R" and "PE" up to a width of 100 mm can be applied by the DEKOMAT 1. Core diameter of rolls: 41 mm. The machine can be used when the clearance between pipe and wall or bottom of the ditch exceeds 250 mm.

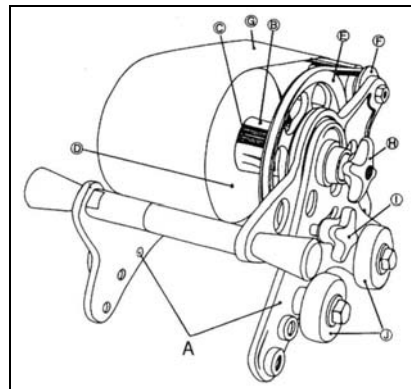

The DEKOMAT 1 consists of two aluminium frames (A1/A2) to which a steel sleeve (B) equipped with three moveable, longitudinally-grooved roller (C) are attached and onto which the tape roll (C) is pushed and fixed in position. Aluminium frame (A2) carries the driving wheel (E) and the winding device (F) for the interleaving (G) of the "AS", "S" and

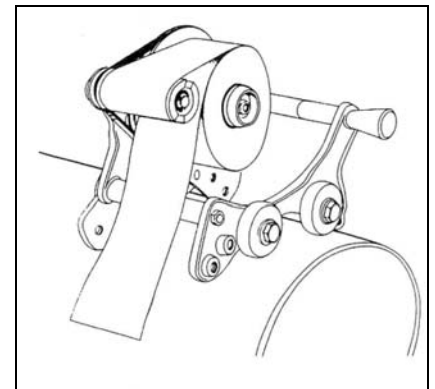

"N" tapes, the set screw (H) for the step less adjustment of the wrapping tension, the adjustment of the width of overlap (I) and the four wheels (J).

Net weight approx. 3 kg

Special types

The DEKOMAT 1 is also available as

DEKOMAT 1/150
for the wrapping of 150 mm wide
BUTYLEN-Tapes

DEKOMAT 1 FZM
equipped with special barrel
shaped wheels for BUTYLEN tape
wrapping on fibre cement coated
steel pipes

Handling

Insertion of BUTYLEN Tape roll

BUTYLEN Tapes "AS", "S" and "N" are supplied with interleaving. Slip BUTYLEN Tape roll (D) onto steel sleeve equipped with three rollers mounted on bearings. Take the beginning of the BUTYLEN Tape roll underneath the winding spool for the interleaving and press it on the steel pipe. Insert the interleaving (G) into the slot of the winding spool (F). Adjust width of overlap with the aid of the set

screw (I) on the aluminium frame (A2) and fix in position. Regulate tape tension with set screw (H).

Tape wrapping

Place DEKOMAT on steel pipe primed with BUTYLEN-Primer. Firmly press beginning of tape onto steel pipe. When moving the DEKOMAT around the pipe, all four wheels must stay in contact with the pipe surface. From the top of the pipe downwards to about

90°, the unwinding BUTYLEN Tape holds the DEKOMAT tightly on the pipe surface. Within this area, the unit does not have to be held by hand. To wrap the lower part of the pipe, the DEKOMAT has to be pulled towards the bottom, around it and upwards again on the other side. In the lower pipe zone, the four wheels of the DEKOMAT also must always stay in contact with the pipe.

Extension

The DEKOMAT 1 is designed for the spiral wrapping of 50 and 100 mm wide BUTYLEN-Tapes on pipes from DN80 and on bends from DN100. The standard setup of DEKOMAT 1 allows wrapping of 50 mm wide tapes. For use of 100 mm wide

BUTYLEN tapes the delivered spare parts for extension (spare part No. 32, 35 and 36) have to be mounted as follows.

After dismounting of stop nut (M 8) and plastics cone handle remove

opposite side panel (A, No. 3). Screw extending rods No. 32 and 35 into frame rods No. 31 and 34. Place plastics liner No. 35 onto extending rod No. 36. Finally mount opposite side panel with stop nut and plastics cone handle.

Spare parts

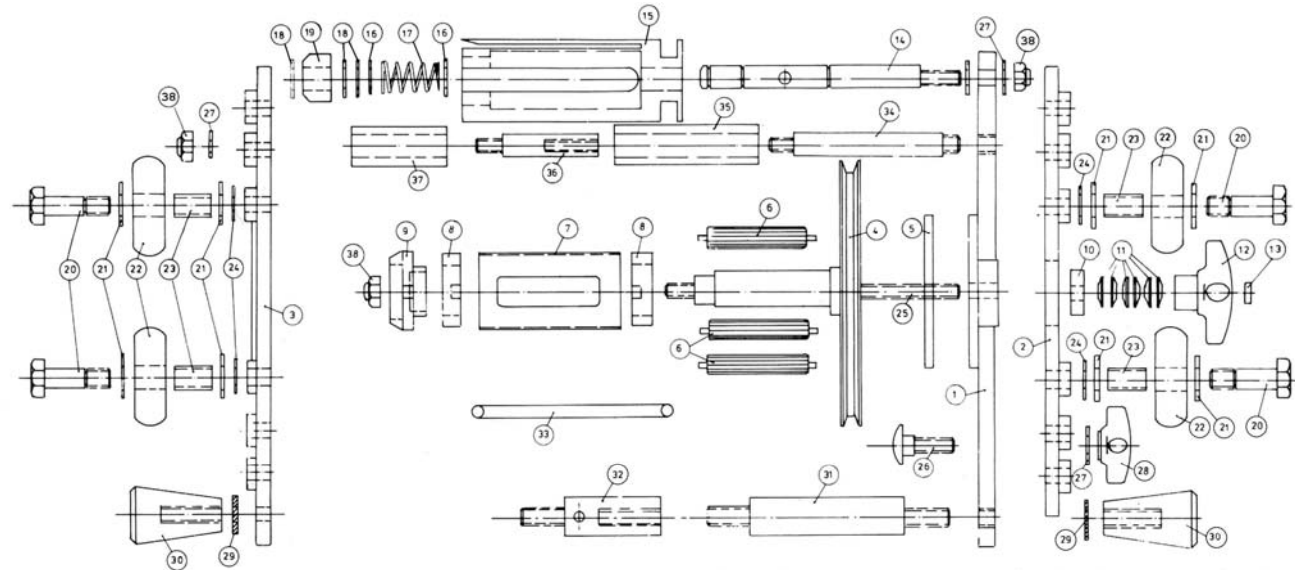

No.	Description	Quantity
1	Side panel	1
2	Side panel segment	1
3	Opposite side panel	1
4	Main axle	1
5	Brake lining	1
6	Brake roller	3

No.	Description	Quantity
7	Casing for brake roller	1
8	Brake roller bearing	2
9	Axle head	1
10	Ball bearing	1
11	Spring washer	6
12	Star handle	1
13	Lock nut	1
14	Release film take up axle	1
15	Release film take up core	1
16	Supporting ring for spring	2
17	Compression spring	1
18	Lock washer	3
19	Stabilizer	1
20	Wheel shaft	4
21	Washer	8
22	Wheel (Teflon)	4
23	Liner	4

No.	Description	Quantity
24	Lock washer	4
25	Threaded rod main axle	1
26	Carriage bolt M 8 x 25	1
27	Washer	4
28	Star handle	1
29	Fan disk washer	2
30	Cone knob	2
31	Handle	1
32	Extension for handle	1
33	Transmission belt	1
34	Connecting rod	1
35	Liner for connecting rod	1
36	Extension for connecting rod	1
37	Liner for extension	1
38	Stop nut	3
39	Release film take up kit	1
40	Wheel kit	4

DEKOTEC GmbH

P.O.Box 150120 • 51344 Leverkusen • Germany
 tel: +49-(0)214-2602-0 • fax: +49-(0)214-2602-318
 www.DEKOTEC.net • info@DEKOTEC.net

Our literature, data sheets and recommendations represent our best knowledge at the time of printing but are in no way legally binding on us. Values and properties shown in diagrams and tables are

typical properties, which are not subject to any guarantee. Our liability is limited as per our standard terms and conditions of sale.

No 05 issue: 02/11 DEKOMAT 1